



BASSO[®]

ITALIAN RACING PASSION

2020
COLLECTION
BOOK

DIAMANTE 31



#WEAREBASSO
#ITALIANRACINGPASSION
#RIDEBETTERIDEBASSO

DNA

Fine Racing Bikes, Functionally Beautiful, Beautifully Functional, Made to Race, Made to Win, Made to Last, Made by Basso.

An extremely authentic brand, wholly dedicated to improving the cycling experience through original, exciting and unique solutions built for reliable, long-lasting, race-winning performance.

Bici da corsa pregiate, belle ma non solo: meravigliosamente funzionali, per le corse, per le vittorie, per durare nel tempo. BASSO è Italian Racing Passion.

Un marchio estremamente autentico, interamente dedicato a migliorare l'esperienza ciclistica attraverso soluzioni originali e uniche, costruite per prestazioni affidabili, durature e vincenti.



BASSO TECHNOLOGY



WIND SHAPE

Aerodynamic shapes for maximum air penetration.

Forme aerodinamiche per la massima penetrazione dell'aria.



CARBON TECH

We use sheets with fibers oriented at 0°, 22°, 45° and 3 types of woven carbon filaments: 1K, 3K and UD.

Utilizziamo fibre orientate a 0°, 22° e 45° e tre tipi di carbonio 1K, 3K and UD.



UCI APPROVED

The frame is U.C.I. approved.

Il telaio è approvato dall'U.C.I.



BLADE FRONT

Semi-integrated front fork/frame/stem/headset.

Forcella e attacco semi-integrati al telaio.



DIRECT MOUNT

Frame designed for double pivot direct mount brakes.

Telaio sviluppato per freni direct mount doppio pivot.



INTEGRATED SEATPOST

Integrated seatpost clamp

Bloccaggio reggisella integrato al telaio



TAPERED HEADSET

Headset and fork 1-1/8" to 1.5" for more rigidity.

Serie sterzo e forcella da 1-1/8" a 1.5" per una rigidità superiore.



DOUBLE FIT

The frame can be used with mechanical or electronic group.

Il telaio può essere utilizzato con gruppo meccanico o elettronico.



ALLOY FREE

Monocoque frame without aluminium reinforcement parts.

Telaio monoscocca senza parti di rinforzo in alluminio.



DISC

Frame designed for disc brakes

Telaio pensato e realizzato per l'uso del freno a disco.



FROM SINGLE TO DOUBLE

From single to double chainring

Modificabile per utilizzo dalla singola alla doppia corona



COMFORT KIT and integrated spacers

From RACING to COMFORT position with the same bike. Choose between 4 and more different approaches according to your riding style. With COMFORT KIT and additional integrated spacers, you can obtain from 1 to several centimeters higher position, maintaining the frame's characteristics of riding and precision. The Kit and three 5mm spacers are included with every frame listed here on the right.

Dalla posizione RACING alla posizione COMFORT con la stessa bici. Scegli tra 4 e più diversi abbinamenti in base al tuo stile di guida. Con COMFORT KIT e gli ulteriori distanziatori integrati puoi ottenere una posizione più alta da 1 a diversi centimetri, mantenendo le caratteristiche del telaio di guida e precisione. Il kit e tre spessori da 5 mm sono inclusi in ogni telaio elencato qui a destra.

DIAMANTE SV



DIAMANTE



PALTA



3B VIBRATION DAMPENING

The seat clamping is totally masked and invisible on the frame. Not only nice to look at but also technically innovative. Getting way ahead of the usual clamp-ring/screw holding the seat post, or the extra bulking knot on the frame to house the seat screw; The 3B-BASSO (pat.) triple point fixing becomes a solid structure between seat-post and seat-tube. This system is slim, invisible and strong. In addition to all of this the extra rubber gusset in connection with the 3B-BASSO (pat.) has an anti vibration function which anyone can appreciate on rough surface roads.

Il bloccaggio sella è totalmente mascherato e invisibile sul telaio. Non solo bello da vedere, ma anche tecnicamente innovativo. Lasciandoci alle spalle i tradizionali sistemi come anello/vite per fissare il reggisella, o il rigonfiamento nel carbonio per far posto ad una vite interna, abbiamo sviluppato un sistema nuovo: il sistema di fissaggio "3B-BASSO" (pat.) che utilizza tre punti di bloccaggio creando un corpo solido fra reggisella e tubo sella. Questo sistema è leggero, invisibile e forte. In aggiunta a queste caratteristiche, abbiamo inserito uno spessore in gomma che abbinato al "3B-BASSO" (pat.) ha una funzione anti vibrazione. Tutti potranno apprezzarne il comfort extra che ne deriva specialmente su strade con superficie sconnessa.

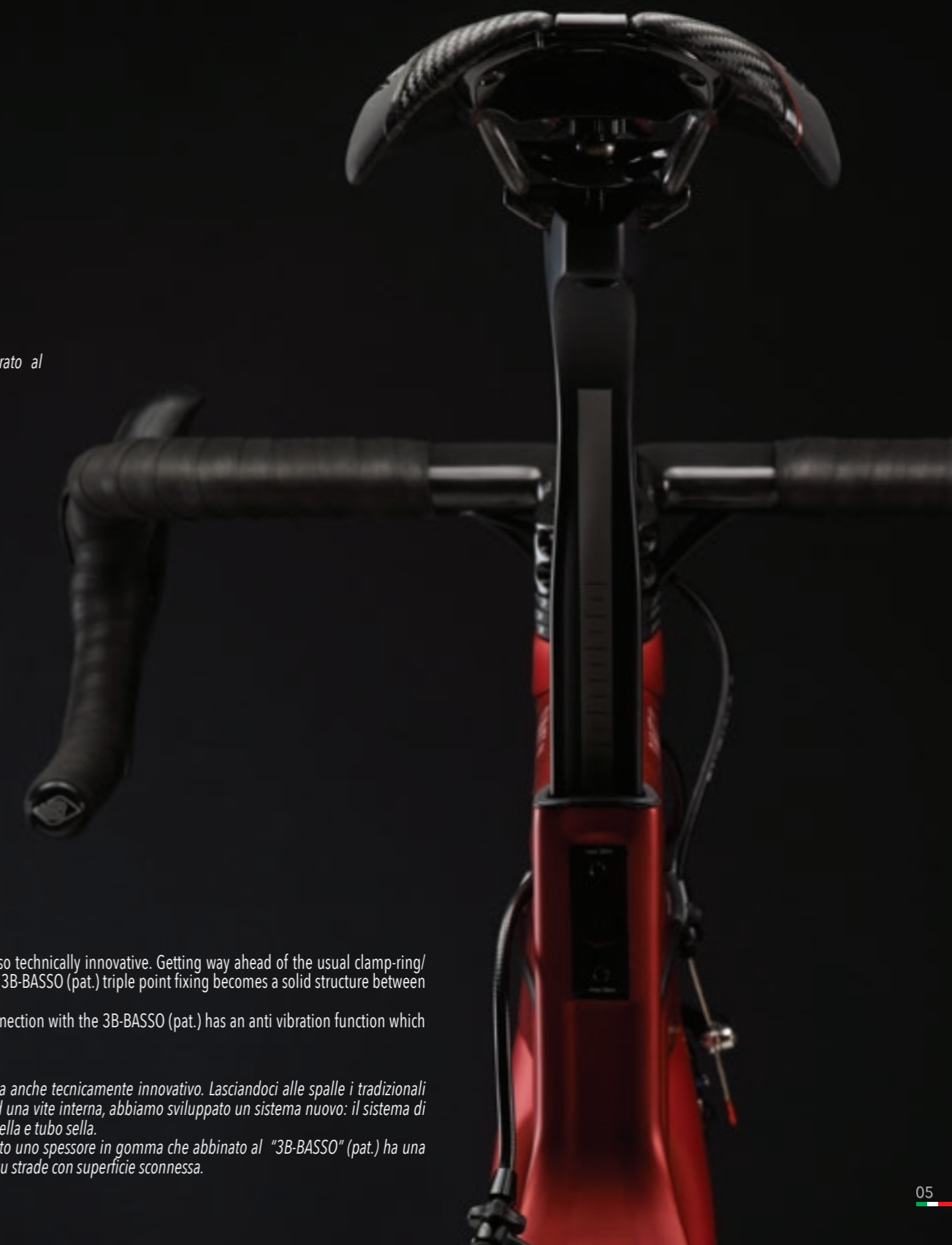

BASSO FRAME TECHNOLOGY

DIAMANTE SV®

100% 3K Torayca HMCF
T1000 and T800

LAY-UP STRUCTURE:
Top tube: 1 x 0° + 1 x 30° + 2 x 45°. **Down tube:** 1 x 0° + 1 x 30° + 2 x 45°.
HT: 2 x 0° + 3 x 30° + 1 x 90°. **ST:** 1 x 0° + 1 x 30° + 1 x 45° + 1 x 90°.
CS and ST: 2 x 0° + 2 x 30° + 1 x 45°

DIAMANTE®

100% 1K Torayca HMCF
T1000 and T800

LAY-UP STRUCTURE:
Top Tube: 1 x 0° + 1 x 22° + 2 x 45°. **Down tube:** 2 x 0° + 1 x 22° + 2 x 45°.
HT: 2 x 0° + 3 x 45°. **ST:** 1 x 0° + 3 x 22°.
CS and ST: 1 x 0° + 3 x 22° + 1 x 45°

NEW ASTRA®

100% 3K Torayca HMCF
T700-MR60

LAY-UP STRUCTURE:
Top Tube: 1 x 0° + 1 x 22° + 2 x 45°. **Down tube:** 2 x 0° + 1 x 22° + 2 x 45°.
HT: 2 x 0° + 4 x 45°. **ST:** 1 x 0° + 3 x 22°.
CS and ST: 1 x 0° + 3 x 22° + 1 x 45°.

NEW UENTA®

100% UD Torayca
TR50 and MR60

LAY-UP STRUCTURE:
Top Tube and Down Tube: 1 x 0° + 1 x 22° + 2 x 45°
HT: 2 x 0° + 4 x 45° **ST:** 1 x 0° + 3 x 22°
CS and ST: 1 x 0°, 3 x 22° + 1 x 45°

PALTA®

100% 3K Torayca HMCF
T700-MR60

LAY-UP STRUCTURE:
Top Tube: 1 x 0° + 1 x 22° + 2 x 45°. **Down tube:** 2 x 0° + 1 x 22° + 2 x 45°.
HT: 2 x 0° + 4 x 45°. **ST:** 1 x 0° + 3 x 22°.
CS and ST: 1 x 0° + 3 x 22° + 1 x 45°.

KONUS®

100% Torayca HMCF
T700

LAY-UP STRUCTURE:
Top Tube: UD Carbon 45°/0°/90° 3K with reinforced sections.
Seat Tube: UD Carbon 30°/0°. **Bottom Bracket:** UD 45°/0° 3K flat with reinforced sections. **TT-DT:** UD 30°/0°. **SS-CS:** UD 45

VIPER®

Steel Alloy
Chrome-Molybdenum

LAY-UP STRUCTURE:
Top tube: thickness 0,60/0,40/0,60 section 23x35
Seat Tube: thickness 0,80/0,45/0,60 section d 31,7
Down Tube: thickness 0,60/0,45/0,60 section 42x35



INDEX

BIKE



ROAD

- 10 Diamante SV
- 18 Diamante
- 26 Astra **NEW**
- 32 Venta **NEW**

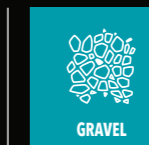

GRAVEL

38 Palta **UPGRADED**



TRI | CRONO

44 Konos



STEEL

46 Viper

Purple Label 48



59

Apparel 52

Wheels 60

Accessories 62



DIAMANTE SV®

A fine racing bike has one job and one job only: to aid its rider to go as fast as possible, under control and by consuming less energy. This is the design input behind the development of the DIAMANTE SV. Extreme efficiency, reactivity and control render this frame capable of conferring great speed, hence the moniker SV, or SUPER VELOCE.

Every tube in the Diamante SV's construction has been optimized terms of its internal structure and external form, using the most sophisticated ultra-high modulus carbon fibers available, to render the bike astoundingly reactive and efficient. It is however the external form of these very tubes that have been meticulously studied to confer an overall aerodynamic advantage that benefits the rider in a versatile manner. Sensible aero design coupled with an extremely solid structure and race proven, rider approved Basso geometry make for a speed demon that handles like a supercar. Super Veloce in all situations the DIAMANTE SV begs for speed whether you are climbing, sprinting or descending.

If the diamond is an example of perfection, then the DIAMANTE SV warrants its name as it encompasses all of the expertise the Basso brand has accumulated in over 40 years of experience constructing fine racing bikes by hand. Made to race, made to win, made to last, made by Basso.

La bici da corsa dei vostri desideri ha un solo scopo: aiutare il suo pilota ad andare il più velocemente possibile, in sicurezza e consumando la minor energia possibile. Questo è l'input progettuale alla base dello sviluppo di DIAMANTE SV. Estrema efficienza, reattività e controllo rendono questo telaio in grado di offrire grande velocità; da qui la sigla SV, o SUPER VELOCE.

Ogni tubo nella costruzione della Diamante SV è stato ottimizzato in termini di struttura interna e forma esterna, utilizzando le più sofisticate fibre di carbonio ad altissimo modulo disponibili, per rendere la bici sorprendentemente reattiva ed efficace. È tuttavia la forma esterna di questi stessi tubi meticolosamente studiati che danno alla bici la capacità di fornire un vantaggio aerodinamico straordinario a beneficio del ciclista. Il design aerodinamico abbinato ad una struttura estremamente solida e collaudata in gara, uniti alla geometria Basso sviluppata per le gare, creano una macchina dedicata alla velocità, che si maneggia come una supercar. Super Veloce in tutte le situazioni, la DIAMANTE SV richiama alla velocità sia in salita, che nello sprint, che in discesa.

Se il diamante è un esempio di perfezione, allora il DIAMANTE SV merita il suo nome in quanto racchiude tutta l'esperienza che il marchio Basso ha accumulato in oltre 40 anni di storia nella costruzione di perfette bici da corsa. Diamante SV: costruito per correre, per vincere, per durare.

TECHNOLOGY



OPTIONAL GROUPS

- SUPER RECORD EPS 12S** - 34/50 or 39/53 or 36/52
- SUPER RECORD 12S** - 34/50 or 39/53 or 36/52
- DURA ACE** - 34/50 or 39/53
- ULTEGRA Di2** - 34/50 or 39/53 or 36/52
- DURA ACE Di2** - 34/50 or 39/53
- ULTEGRA** - 34/50 or 39/53 or 36/52

OPTIONAL WHEELS

- DISC:** Campagnolo BORA WTO 45, Campagnolo BORA ONE 35, Microtech MR38, Microtech MR LITE
- RIM:** Campagnolo BORA WTO 45, Campagnolo BORA ONE 35, Microtech MCT

STANDARD SIZE COMPONENTS ON ASSEMBLED BIKES

bike size	45	48	51	53	56	58	61
handlebar width (mm)	420	440	440	440	440	440	460
stem length (mm)	90	100	100	110	110	120	130
crank length (mm)	170	170	172.5	172.5	172.5	172.5	175

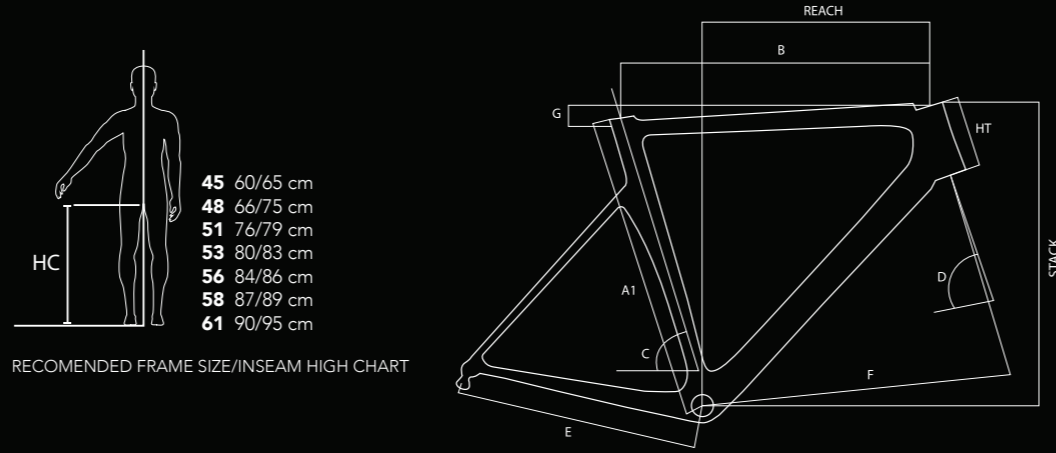

- 45 60/65 cm
- 48 66/75 cm
- 51 76/79 cm
- 53 80/83 cm
- 56 84/86 cm
- 58 87/89 cm
- 61 90/95 cm

RECOMENDED FRAME SIZE/INSEAM HIGH CHART

	45	48	51	53	56	58	61
A1 bike size	45	48	51	53	56	58	61
B top tube (mm)	505	515	525	545	560	575	590
R reach (mm)	381	382	386	393	395	397	396
S stack (mm)	493	493	518	530	557	580	614
C seat tube angle (degree)	76	75	75	74	73.5	73	72.5
D steering tube angle (degree)	71.8	71.8	72	72.3	73.5	73.5	74
E chain-stay length (mm)	400	400	400	400	402	406	406
F bb to fork length (mm)	573	574	583	592	590	599	602
G slope (mm)	70	43	38	34	33	38	45
HT headtube (mm)	90	90	115	127	145	169	203





BIKE SPECS

weight: 7.2 Kg

handlebar - Microtech Quantum Carbon Compact
stem - Diamante Alloy
seatpost - Diamante Carbon

group - Dura Ace Di2
wheels - Microtech MR38 Clincher
saddle - San Marco Mantra Carbon FX



BIKE SPECS

weight: 6.7 Kg

handlebar - Microtech Integra Carbon Compact
 seatpost - Diamante Carbon
 group - Super Record

wheels - Campagnolo Bora Ultra
 saddle - San Marco Mantra Carbon FX

BIKE SPECS

weight: 7.3 Kg

handlebar - Microtech Quantum Carbon Compact
 stem - Diamante Alloy
 seatpost - Diamante Carbon

group - Ultegra
 wheels - Microtech MRLite
 saddle - San Marco Mantra Carbon FX



BIKE SPECS

weight: 7.5 Kg

handlebar - Microtech Quantum Carbon Compact
stem - Diamante Alloy
seatpost - Diamante Carbon

group - Ultegra Di2
wheels - Microtech MR38 Clincher
saddle - San Marco Mantra Carbon FX



DIAMANTE®

In nature the diamond comes about through years and years of pressure that result in a precious gem whose beauty and timelessness knows no rival. The Basso Diamante too is the result of years of hard work, research and pressure to develop the finest racing bike that is timeless not only in terms of performance and reliability but also in form and beauty.

Diamante is a true representation of exactly what a fine, authentic Italian racing bike should be. Using only the finest high modulus carbon fiber from Toray the Basso engineering staff have produced a frame capable of efficient performance that lasts and excels over all terrain. Tube shapes and carbon layup allow for a reactive frame with bottom bracket flex of a mere 0.2mm and a head tube torsion of an amazingly low 0.4mm... a 50% improvement over previous models. Available in both disc and rim versions, the new frame has been optimized to allow for up to 28mm tires, thus increasing even further the Diamante's versatility.

Add to the tried, trusted and approved Basso geometry an elegant front end that allows the flexible rider to achieve an extremely aggressive position while allowing the more upright rider to maintain a front end more compact in appearance. If looking good is half the battle then the Diamante has the battle won as its every fiber is meant for moving faster and in a more efficient manner yet its form is an example of undeniable Italian design and class. Functionally beautiful and beautifully functional: Basso Diamante.

In natura il diamante nasce attraverso anni e anni di compressione che si traducono in una gemma preziosa la cui bellezza senza tempo non conosce rivali. Anche Basso Diamante è il risultato di anni di duro lavoro, ricerca e concentrazione per sviluppare la migliore bici da corsa che è senza tempo non solo in termini di prestazioni e affidabilità, ma anche in forma e bellezza.

Diamante è una rappresentazione fedele di come dovrebbe essere una vera e propria bici da corsa italiana. Utilizzando solo la migliore fibra di carbonio ad alto modulo di Toray, lo staff tecnico di Basso ha prodotto un telaio in grado di offrire prestazioni efficienti che durano nel tempo, ed eccelle in ogni aspetto. Le forme del tubo e la stratificazione del carbonio consentono un telaio reattivo con una flessione del movimento centrale di soli 0,2 mm e una torsione del tubo sterzo incredibilmente bassa di soli 0,4 mm ... un miglioramento del 50% rispetto ai modelli precedenti. Disponibile nelle versioni disco e con freni tradizionali dual pivot, il nuovo telaio è stato ottimizzato per consentire pneumatici fino a 28 mm, aumentando così ulteriormente la sua versatilità.

La geometria Basso è frutto di anni di esperienza nelle competizioni, ma non vuole essere un limite per il ciclista che chiede una posizione più rilassata: la parte superiore del tubo sterzo è fornita di spessori modulabili e integrati uno all'altro per consentire al ciclista più esperto di raggiungere una posizione estremamente aggressiva, ma permettendo a tutti gli altri utilizzatori di avere una posizione più rialzata senza togliere nulla all'aspetto compatto ed elegante della bici. Se avere un bell'aspetto è metà della battaglia, allora Diamante ha vinto la battaglia poiché ogni sua fibra è pensata per muoversi più velocemente e in modo più efficiente, ma la sua forma è un esempio di innegabile design e classe italiana. Funzionalmente bello e meravigliosamente funzionale: Basso Diamante.

TECHNOLOGY



OPTIONAL GROUPS

SUPER RECORD EPS 125 - 34/50 or 39/53 or 36/52

DURA ACE - 34/50 or 39/53

SUPER RECORD 125 - 34/50 or 39/53 or 36/52

ULTEGRA DI2 - 34/50 or 39/53 or 36/52

DURA ACE DI2 - 34/50 or 39/53

ULTEGRA - 34/50 or 39/53 or 36/52

OPTIONAL WHEELS

DISC: Campagnolo BORA WTO 45, Campagnolo BORA ONE 35, Microtech MR38, Microtech MR LITE

RIM: Campagnolo BORA WTO 45, Campagnolo BORA ONE 35, Microtech MCT

STANDARD SIZE COMPONENTS ON ASSEMBLED BIKES

bike size	45	48	51	53	56	58	61
handlebar width (mm)	420	440	440	440	440	440	460
stem lenght (mm)	90	100	100	110	110	120	130
crank lenght (mm)	170	170	172.5	172.5	172.5	172.5	175

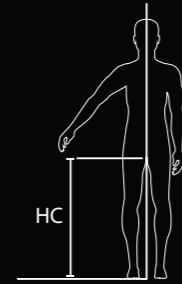

45 60/65 cm
 48 66/75 cm
 51 76/79 cm
 53 80/83 cm
 56 84/86 cm
 58 87/89 cm
 61 90/95 cm

RECOMENDED FRAME SIZE/INSEAM HIGH CHART

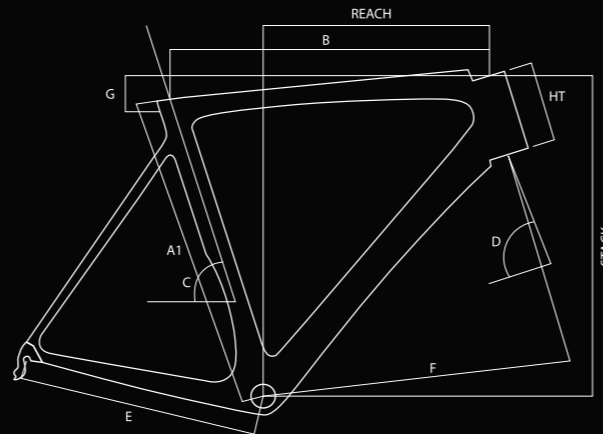

A1	bike size	45	48	51	53	56	58	61
B	top tube (mm)	505	515	525	545,4	560	575	590
R	reach (mm)	379,5	377,5	383,6	390,4	392,2	394,8	393,2
S	stack (mm)	503,4	513,1	527,8	540,3	566,6	589,6	624,2
C	seat tube angle (degree)	76	75	75	74	73.5	73	72.5
D	steering tube angle (degree)	71.8	71.8	72	72.3	73.5	73.5	74
E	chain-stay lenght (mm)	400	400	400	400	402	406	406
F	bb to fork lenght (mm)	573,6	574,8	583,8	591,9	589,5	598,9	602,2
G	slope (mm)	86,5	71,7	57,3	52,2	50,7	55,9	63,5
HT	headtube (mm)	100	110	125	137	155	179	213





BIKE SPECS

weight: 6.5 Kg

handlebar - Microtech Integra Carbon Compact
seatpost - Diamante Carbon
group - Ultegra D12

wheels - Campagnolo Bora WTO 45
saddle - San Marco Mantra Carbon FX



BIKE SPECS

weight: 6.8 Kg

handlebar - Microtech Quantum Carbon Compact
stem - Diamante Alloy
seatpost - Diamante Carbon

group - Super Record
wheels - Microtech MR38 Clincher
saddle - San Marco Mantra Carbon FX





BIKE SPECS

weight: 7.5 Kg

handlebar - Microtech Integra Carbon Compact
 seatpost - Diamante Carbon
 group - New Chorus 12 Speed

wheels - Campagnolo Bora One 35
 saddle - San Marco Mantra Carbon FX

BIKE SPECS

weight: 6.9 Kg

handlebar - Microtech Quantum Carbon Compact
 stem - Diamante Alloy
 seatpost - Diamante Carbon

group - Super Record
 wheels - Microtech MR38 Clincher
 saddle - San Marco Mantra Carbon FX

ASTRA®

For nearly 30 years the Astra model has been made in the Basso factory in northeastern Italy. The latest in this long line of prestigious frames is one that generates a great deal of pride for the entire Basso staff as it represents the cumulative knowledge and experience gained from building the previous 5 models.

The all-new 2020 Astra pushes the limits farther than any version before it and does so with a good dose of style. The latest version of the Astra model incorporates a great deal of technology that derives from its upper tier siblings and adopts a design that follows a tighter family feeling than ever before.

Astra incorporates the tried, tested and racer approved Basso geometry and mates it with a sophisticated tube structure that adds efficiency thanks to both form and function. While aerodynamic thanks to tube profiles the new model is also more efficient thanks to the functional properties of the carbon structure.

A larger, more solid head tube joins with an extremely efficient downtube, made more so thanks to a particular form highlighted by its characteristic side "channel". Both tubes couple with completely redesigned chain stays to confer fantastic power transfer thanks to a solid, reactive complete unit of lower tubes (head tube, down tube, chainstays).

Add to the prestigious structure of the new model several design characteristics most commonly seen in higher priced offerings and you have not only a podium worthy race bike but one that represents a fantastic value proposition. The integrated seatpost clamp, internally routed cables, premium paint job and extremely minimal and sophisticated graphic design make for a beautiful ride that punches well above its weight in terms of tech, performance, reliability and value.

Per quasi 30 anni il modello Astra è stato realizzato nello stabilimento Basso nell'Italia nord-orientale. L'ultima di questa lunga serie di prestigiosi telai che portano questo nome ci rende molto orgogliosi in quanto rappresenta la conoscenza accumulata e l'esperienza acquisita nella costruzione dei 5 modelli precedenti.

La nuovissima Astra 2020 spinge i limiti oltre ogni versione precedente e lo fa con lo stile che ci contraddistingue. Astra è ora fornita di molti particolari tecnici derivanti dai nostri modelli più essenzialmente racing, di cui ha adottato anche alcune forme aerodinamiche che caratterizzano la famiglia.

Astra adotta la geometria Basso collaudata e approvata nelle gare e la abbina ad una attenta stratificazione del carbonio in ogni singolo tubo, questo aggiunge efficienza sia alla forma che alla funzione. Il risultato ottenuto è di maggiore aerodinamicità fornita dai profili dei tubi, e più efficienza grazie alle proprietà funzionali della struttura in carbonio.

Il tubo sterzo più grande e più solido si unisce al tubo obliquo, reso più resistente dalla forma che porta in evidenza i caratteristici canali laterali. I rinforzi laterali si accompagnano fino a raggiungere i due assi posteriori del telaio, completamente riprogettati per dare un trasferimento di potenza straordinario, ottenuta dall'effetto di "corpo unico" fra tubo sterzo, tubo obliquo e foderi orizzontali.

I pregi della nuova Astra 2020 non si limitano alle caratteristiche prestazionali del telaio, a queste abbiamo aggiunto altri particolari dei nostri modelli di alta gamma per darvi una bici da corsa non solo degna del podio, ma che ha anche un rapporto qualità/prezzo fantastico. Il morsetto reggisella integrato, i cavi interni, il lavoro di verniciatura di alta qualità e il design grafico estremamente minimale e sofisticato, danno alla nuova Astra un valore aggiunto alle sue caratteristiche di tecnologia, prestazioni e affidabilità.

TECHNOLOGY



OPTIONAL GROUPS

CHORUS - 34/50 or 36/52

DURA ACE D12 - 34/50 or 36/52 or 39/53

ULTEGRA - 34/50 or 36/52 or 39/53

ULTEGRA D12 - 34/50 or 36/52 or 39/53

OPTIONAL WHEELS

DISC: Microtech MR38 - Microtech MRLite

STANDARD SIZE COMPONENTS ON ASSEMBLED BIKES

bike size	45	48	51	53	56	58	61
handlebar width (mm)	420	440	440	440	440	440	460
stem length (mm)	90	100	100	110	110	120	130
crank length (mm)	170	170	172.5	172.5	172.5	172.5	175

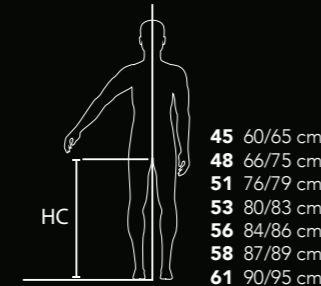

RECOMENDED FRAME SIZE/INSEAM HIGH CHART

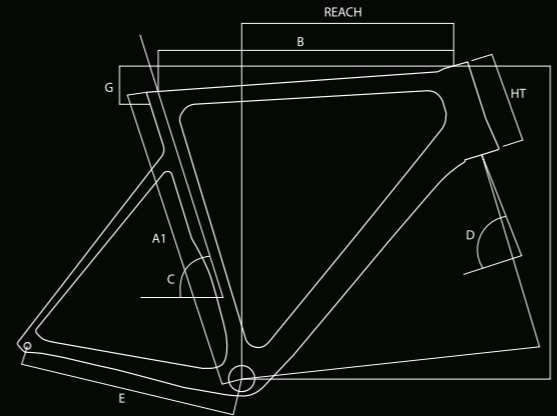

A1	bike size	45	48	51	53	56	58	61
B	top tube (mm)	505	515	525	545	560	575	590
R	reach (mm)	373.6	373.7	377.2	382.9	385.1	387.5	388.7
S	stack (mm)	527.1	527.1	551.6	564.1	590.5	613.5	638.4
C	seat tube angle (degree)	76	75	75	74	73.5	73	72.5
D	steering tube angle (degree)	71.8	71.8	72	72.3	73.5	73.5	74
E	chain-stay length (mm)	400	400	400	400	402	406	406
F	bb to fork length (mm)	575.5	575.7	585.2	592.0	589.5	598.7	601.8
HT	headtube (mm)	125	125	150	162	180	204	228



BIKE SPECS

weight: 8.4 Kg

handlebar - Microtech XL
stem - Diamante Alloy
seatpost - Astra Carbon

group - New Chorus 12speed
wheels - Microtech MR38 Clincher
saddle - San Marco GND



BIKE SPECS

weight: 8.4 Kg

handlebar - Microtech XL
stem - Diamante Alloy
seatpost - Astra Carbon

group - Ultegra Di2
wheels - Microtech MRLite
saddle - San Marco GND



VENTA®

After precisely two decades of fantastic performance, ground breaking design and unrivaled craftsmanship, the Venta model celebrates its 20th year. Basso is proud to celebrate this specific model's glorious past and present by introducing a completely new design that is as technically sound as it is beautiful. The new model, available in both rim and disc brake versions, is the first model that follows a new design principle for Basso that offers a stronger family feeling and more coherence in terms of design between all models, regardless of their position within the range.

The 20th anniversary Venta model blends head turning and function-driven design with performance that makes it a more than capable race-ready steed. Sleek lines and minimalist graphics make sure that this frame perhaps one of the most elegant within its segment. While aesthetics go a long way into defining the beauty of the Venta model it is the craftsmanship that sets this frame apart from its competition. Made with the same extreme attention to quality and detail used to make the most premium frames in the range, the Venta represents a fantastic value proposition. It's beautiful shape and construction meet with advanced features, generally reserved for higher tier offerings, thus making for an even more interesting offer. Internal cable routing and integrated seat post clamp make for a clean aesthetic while the oversized bottom bracket and reinforced head tube junction make for an extremely reactive construction.

The Venta, even after 20 years continues to represent the fantastic design premise of the original model. The latest version is a testament to the fact that impeccable craftsmanship, performance and design, built to race and built to last are qualities found throughout the entire range of Basso Bikes, no matter their price point.

Sono passati vent'anni dalla nascita del primo modello VENTA in casa Basso. Sono stati anni di prestazioni fantastiche, design innovativo e sviluppo della conoscenza nella costruzione di telai in carbonio. Basso è orgoglioso di celebrare il glorioso passato presentando il nuovo VENTA 2020 dal design completamente nuovo e tecnicamente performante quanto bello. Venta è disponibile sia nella versione con freni tradizionali che con freno a disco, è il primo modello che segue un nuovo principio di design per Basso volto ad offrire una maggior coesione nelle forme per dare una sensazione di famiglia più forte e una maggiore coerenza in termini di design tra tutti i modelli, indipendentemente dalla loro posizione all'interno della gamma.

Il modello Venta 20° anniversario è studiato nei minimi particolari per avere un aspetto moderno e accattivante, e per essere pronto anche ad una guida aggressiva. Linee eleganti e grafica minimalista fanno sì che questa bici sia forse una delle più eleganti nel suo segmento. La bellezza del modello Venta non sarebbe abbastanza per noi che vogliamo che i nostri prodotti si distinguano soprattutto per le loro prestazioni; realizzato con estrema attenzione alla qualità e ai dettagli come per la produzione dei telai più pregiati della gamma, il Venta rappresenta una proposta di valore superiore al suo segmento di mercato: il passaggio dei cavi interno e il bloccaggio del reggisella integrato assicurano un'estetica pulita, mentre il movimento centrale sovradimensionato e la giunzione rinforzata del tubo sterzo creano una struttura estremamente reattiva.

Il Venta, anche dopo 20 anni, continua a rappresentare il design innovativo del modello originale. L'ultima versione è una testimonianza del fatto che affidabilità, prestazioni e design impeccabili, sono qualità che si trovano in tutta la gamma di bici Basso, in ogni suo modello.

TECHNOLOGY



OPTIONAL GROUPS

105 - 34/50
ULTEGRA - 34/50

OPTIONAL WHEELS

DISC: Microtech MCT DISC
RIM: Microtech Krium

STANDARD SIZE COMPONENTS ON ASSEMBLED BIKES

bike size	45	48	51	53	56	58	61
handlebar width (mm)	420	440	440	440	440	440	460
stem length (mm)	90	100	100	110	110	120	130
crank length (mm)	170	170	172.5	172.5	172.5	172.5	175



45 60/65 cm
48 66/75 cm
51 76/79 cm
53 80/83 cm
56 84/86 cm
58 87/89 cm
61 90/95 cm

RECOMENDED FRAME SIZE/INSEAM HIGH CHART

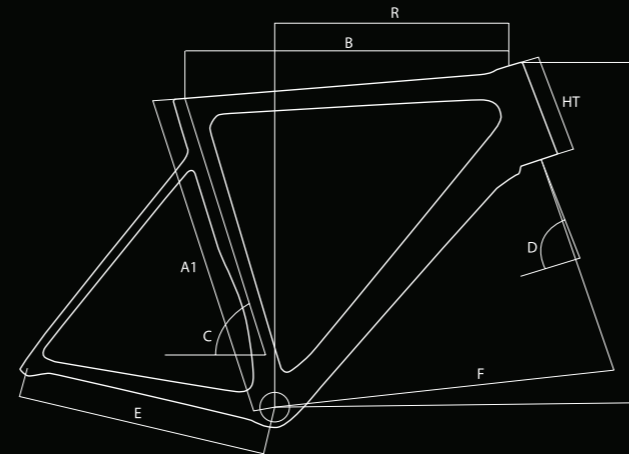

A1	bike size	45	48	51	53	56	58	61
B	top tube (mm)	493.5	505.4	516.3	536.4	550.8	564.0	578.7
R	reach (mm)	374.6	373.9	377.4	383.8	385.9	388.4	389.6
S	stack (mm)	520.2	524.3	548.7	561.2	587.6	610.7	635.5
C	seat tube angle (degree)	76	75	75	74	73.5	73	72.5
D	steering tube angle (degree)	72	71.8	72	72.3	73.5	73.5	74
E	chain-stay length (mm)	400	400	400	400	402	404	405
F	bb to fork length (mm)	572.5	574.9	584.5	591.9	589.5	598.7	601.9
HT	headtube (mm)	120	125	150	162	180	204	228





BIKE SPECS

weight: 8.5 Kg

handlebar - Microtech XL
stem - Microtech XL
seatpost - Venta Alloy

group - Ultegra
wheels - Microtech MCT Disc
saddle - San Marco GND



BIKE SPECS

weight: 8.0 Kg

handlebar - Microtech XL
stem - Microtech XL
seatpost - Venta Alloy

group - Ultegra
wheels - Microtech Krium
saddle - San Marco GND



GRAVEL

PALTA®

When an increasing number of riders break free from the constraints of paved roads and seek the liberty that mixed surface riding provides, we at Basso answer their call with a solution that remains faithful to our tradition and values for the road while optimizing for a new, varied terrain.

While others do gravel, we do Palta...the Basso solution for those wishing to take on adventures without taking route conditions into consideration. The Palta, which in local dialect means mud or dirt, has gained an international following and universal respect thanks to its "specific versatility". If freedom is the name of the game in the gravel sector then Palta is king as it excels in a variety of applications. Perfectly adaptable to road replacement, gravel racing, cross riding or the epic multiday adventure, the Palta is to the gravel world what the multi-tool is to your saddle bag...but without compromises.

With over 40 years of expertise in developing efficient geometries Basso developed an innovative solution that combines both comfort and performance and ensure fantastic handling in all situations. The specially developed Palta fork stands out and is fundamental to allowing for both great versatility amongst varied terrain in addition to a geometry that provides comfort and efficiency while allowing for near road-like positioning if need be.

New terrain, same philosophy. Beautifully functional, functionally beautiful. Made for speed, made to last, made by Basso.

*7 bottle cage bolts for carrying up to three water bottles.

*tires up to 42mm

*100% Torayca High Modulus Carbon Fiber

*front derailleur adapter on request

Quando un numero crescente di ciclisti cerca la libertà uscendo dalle strade asfaltate e cerca una guida non limitata da un solo tipo di terreno, noi di Basso rispondiamo alla loro chiamata con una soluzione che rimane fedele alla nostra tradizione di bici studiate per la strada, ottimizzandone la prestazione per un nuovo utilizzo libero da vincoli.

Mentre altri fanno Gravel, noi facciamo Palta ... la soluzione Basso per coloro che desiderano l'avventura senza preoccuparsi delle condizioni del percorso. Il Palta, che nel dialetto locale significa fango o terra, ha guadagnato un seguito internazionale e un rispetto universale grazie alla sua "versatilità specifica". Se la libertà è il nome più sentito nel settore del Gravel, Palta ne è il re in quanto eccelle in una varietà di sue declinazioni. Perfettamente adattabile alla sostituzione della bici da strada, alla corsa sulla ghiaia, al cross riding o all'avventura epica di più giorni, il Palta è per il mondo del Gravel quello che il multi-tool è per la tua borsa sotto sella ... ma senza compromessi.

Con oltre 40 anni di esperienza nello sviluppo di geometrie efficienti, Basso ha sviluppato una soluzione innovativa che combina comfort e prestazioni e garantisce una maneggevolezza fantastica in tutte le situazioni. La forcella Palta appositamente sviluppata si distingue ed è fondamentale per consentire sia la grande versatilità sui vari terreni, oltre a una geometria che offre comfort ed efficienza con una posizione semi-stradale, se necessario.

Nuovo terreno, stessa filosofia. Splendidamente funzionale, funzionalmente bella. Nata da decenni di esperienza italiana, costruita per la velocità, per durare, per diffondere la filosofia racing di Basso.

* 7 viti per porta borraccia per trasportare fino a tre borracce.

* pneumatici fino a 42 mm

* 100% fibra di carbonio ad alto modulo Torayca

*adattatore per deragliatore anteriore su richiesta

TECHNOLOGY



MUDFEST KIT
ENDURANCE KIT

OPTIONAL WHEELS

Microtech MCT Disc

		XS	S	M	L	XL
A1	bike size (mm)	450	480	520	550	580
B	top tube (mm)	495	510	530	550	565
R	reach (mm)	359,8	365,6	374,8	383,7	388,2
S	stack (mm)	504,6	520,5	541,2	559,2	578,1
C	seat tube angle (degree)	75	74,5	74	73,5	73
D	steering tube angle (degree)	69	69,5	70	71	71
E	chain-stay lenght (mm)	430	430	430	430	430
F	bb to fork lenght (mm)	580,4	587,6	599,5	604,9	615,9
V	drop (mm)	65	65	65	65	65
HT	headtube (mm)	90	105	125	140	160

OPTIONAL GROUPS

SHIMANO GRX D12

SHIMANO GRX

SRAM FORCE 1 CX

SRAM RIVAL 1

STANDARD SIZE COMPONENTS ON ASSEMBLED BIKES

bike size	XS	S	M	L	XL
handlebar width (mm)	420	440	440	460	460
stem lenght (mm)	90	100	100	120	120
crank lenght (mm)	170	172.5	172.5	172.5	172.5

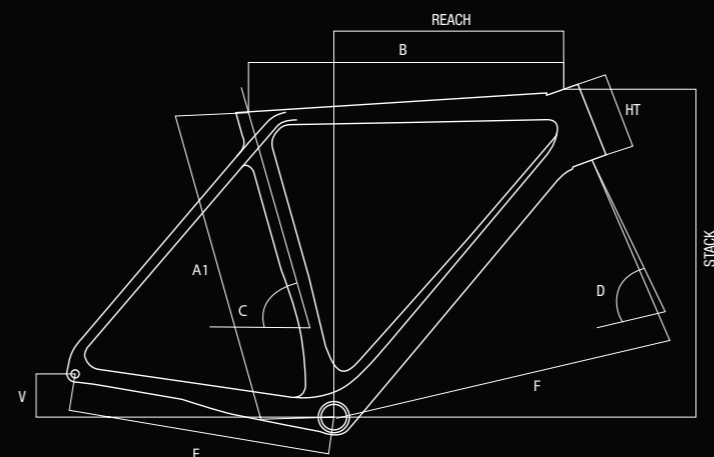



BIKE SPECS

weight: 8.5 Kg

handlebar - Microtech XL
 stem - Diamante Alloy
 seatpost - Palta Carbon

group - SRAM Force 1 CX
 wheels - Microtech MCT Disc
 saddle - San Marco GND

*Options: Mudfest kit



BIKE SPECS

weight: 8.3 Kg

handlebar - Microtech XL
 stem - Diamante Alloy
 seatpost - Palta Carbon

group - Shimano GRX
 wheels - Microtech MCT Disc
 saddle - San Marco GND

*Options: Chain guide



BIKE SPECS

weight: 8.8 Kg

handlebar - Microtech XL
 stem - Diamante Alloy
 seatpost - Palta Carbon

group - SRAM Rival 1
 wheels - Microtech MCT Disc
 saddle - San Marco GND

When the margin between victory and defeat is measured in milliseconds then your equipment must be optimized down to the millimeter and your position dialed to perfection. Whether you are racing against the clock or against other athletes the Konos is your number one ally thanks to its fully adjustable positioning both horizontally and vertically in addition to tube shapes meticulously studied to confer the least amount of aerodynamic drag possible. Aerodynamically superefficient the bike reduces its own drag and allows you, the rider, to minimize your drag via your perfect positioning, tailored to your specific needs.

Quando il margine tra vittoria e sconfitta viene misurato in millesimi, il tuo equipaggiamento deve essere ottimizzato al millimetro e la tua posizione impostata alla maggior aerodinamicità possibile. Sia che tu stia pedalando per migliorare il tuo stesso tempo o in gara contro gli altri, Konos è il tuo alleato numero uno grazie al suo posizionamento completamente regolabile sia in orizzontale che in verticale, oltre alle forme dei tubi meticolosamente studiate per conferire il minor grado di resistenza all'aria possibile. Aerodinamicamente super efficiente, su misura per le tue esigenze specifiche.

TECHNOLOGY



OPTIONAL GROUPS

ULTEGRA D12 - 39/53

WHEELS

Microtech MTT (tubular)

	51	53	55
A1 bike size			
B top tube (mm)	515	530	545
R reach (mm)	396.8	406.9	417
S stack (mm)	487.4	506.8	524.1
C seat tube angle (degree)	75.5	75.5	75.5
D steering tube angle (degree)	73	73	73
E chain-stay lenght (mm)	390	390	390
F bb to fork lenght (mm)	563.6	579.4	595.3
HT headtube (mm)	60	80	100

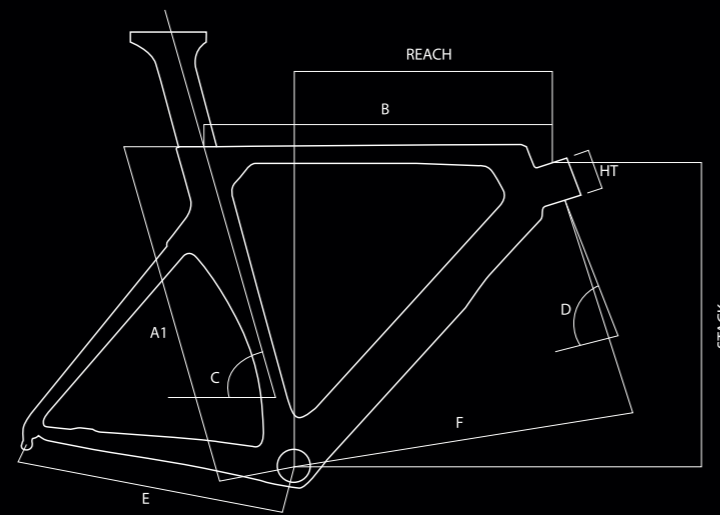

BIKE SPECS

weight: 7.8 Kg

handlebar - Konos Carbon Integrated
seatpost - Konos Carbon Custom
group - Dura Ace Di2

wheels - Microtech MTT 88/85
saddle - San Marco Shorty Fit Carbon

VIPER®



Alcide Basso story starts with the welding of a steel frame. Not content to take the current technology of the time as the Basso standard, Alcide Basso set forth to study, investigate and innovate new methods of construction, material preparation and frame building. That tradition has been maintained throughout Basso's history and the Viper model represents all that was learned during that long journey that looked to perfect steel frame construction. Made by hand in Italy, the Viper blends traditional looks and style with the capability to build modern componentry, thus creating an elegant, sophisticated bike that begs for speed yet offers a ride quality without comparison.

La storia di Alcide Basso inizia saldando telai in acciaio. Ma non soddisfatto della tecnologia disponibile a quel tempo, Alcide Basso iniziò a ricercare e innovare studiando nuovi metodi di selezione e preparazione dei materiali e costruzione del telaio. Quella tradizione è stata mantenuta nella storia di Basso e il modello Viper rappresenta tutto ciò che è stato appreso durante questo lungo viaggio che mira alla perfetta costruzione di un telaio in acciaio. Realizzato a mano in Italia, Viper fonde look e stile tradizionali con la capacità di costruire componenti moderni, creando così una bici elegante e sofisticata che offre non solo velocità ma anche una qualità di guida senza confronti.

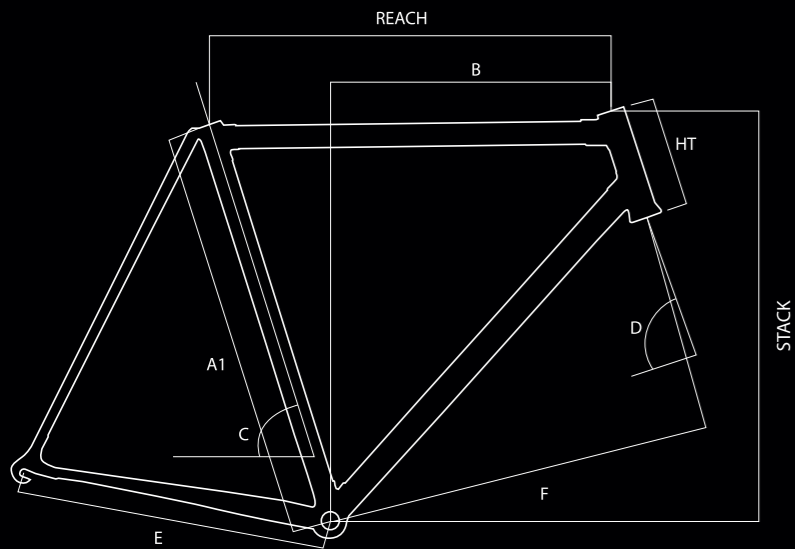

A1	bike size	48	50	52	54	56	58	60
B	top tube (mm)	510	520	535	545	560	570	580
C	seat tube angle (degree)	74,5	74	74	73,5	73,5	73	73
D	steering tube angle (degree)	71.5	72,5	72.5	73	73	73	73
E	chain-stay length (mm)	406	407	409	411	411	413	415
F	bb to fork length (mm)	570	572	583	584	594	599	609
HT	headtube (mm)	90	104	120	136	155	174	194



BIKE SPECS

handlebar - Microtech XL
 stem - Microtech
 seatpost - Microtech 30mm

group - Super Record
 wheels - Campagnolo Bora WTO 45
 saddle - San Marco GND

Purple Label
READY FOR ANYTHING
#WEAREBASSO



PRO RACE JERSEY AND BIB PANTS

Excellent breathability & quick drying properties/ full front zip YKK / three compartment rear pocket / soft silicone band on sleeve edge and lower jersey edge / anti-slip silicone band on legs / CoolMax® padding / anatomic multi-panel cut / brace construction made from breathable mesh / soft internal overlapped stitching for comfort. Composition: 90% Polyester 10% Elastane
Size: XS-S-M-L

Tech Specs p.18

DIAMANTE
Purple Label



BIKE SPECS

weight: 7.8 Kg

handlebar - Microtech Quantum Carbon Compact
stem - Diamante Alloy
seatpost - Diamante Carbon

group - Ultegra
wheels - Microtech MR38 Clincher
saddle - San Marco Shorty Fit Carbon

Tech Specs p.26

ASTRA
Purple Label



BIKE SPECS

weight: 8.4 Kg

handlebar - Microtech XL
stem - Diamante Alloy
seatpost - Astra Carbon

group - Ultegra
wheels - Microtech MRLite
saddle - San Marco GND

Tech Specs p.32

VENTA[®]
Purple Label



BIKE SPECS

weight: 8.6 Kg

handlebar - Microtech XL
stem - Microtech XL
seatpost - Venta Alloy

group - 105
wheels - Microtech MCT Disc
saddle - San Marco GND

Tech Specs p.38

PALTA[®]
Purple Label



BIKE SPECS

weight: 8.8 Kg

handlebar - Microtech XL
stem - Diamante Alloy
seatpost - Palta Carbon

group - SRAM Rival 1
wheels - Microtech MCT Disc
saddle - San Marco GND



AQUA PRO RACE KIT

PRO RACE JERSEY AND BIB PANTS (extra slim fit)

Excellent breathability & quick drying properties/ full front zip YKK / three compartment rear pocket / soft silicone band on sleeve edge and lower jersey edge / anti-slip silicone band on legs / CoolMax® padding / anatomic multi-panel cut / brace construction made from breathable mesh / soft internal overlapped stitching for comfort. Composition: 90% Polyester 10% Elastane
Size: S-M-L-XL-XXL

WIND VEST ISTITUTIONAL

Light and foldable is perfect for your back pockets / reflective back stripes / perfect ventilation with the air panels on your back.
SIZE: S-M-L-XL-XXL



ALIANTE HELMET BLACK | ANTHRACITE

Basso Aliante's structure is based on an innovative design approach which focuses on particular performance parameters of the helmet such as being compact, aerodynamic, ventilated and lightweight. TECHNOLOGY: In-Mould, Adjustable Rol Loc Retention.
CERTIFICATION: (CE: EN 1078 - CP: SC 1203)
SIZE: 2 sizes available
WEIGHT: Gr. 280



BASSO RACING SOCKS

Arch support for good fit / Cushioned panels for comfort and support / Flat toe seam to avoid pressure or irritations / unisex
Size: 39-41 / 42-44 / 45-47



BASSO RACING SOCKS

Arch support for good fit / Cushioned panels for comfort and support / Flat toe seam to avoid pressure or irritations / unisex
Size: 39-41 / 42-44 / 45-47



ALIANTE HELMET SUNSET

Basso Aliante's structure is based on an innovative design approach which focuses on particular performance parameters of the helmet such as being compact, aerodynamic, ventilated and lightweight. TECHNOLOGY: In-Mould, Adjustable Rol Loc Retention.
CERTIFICATION: (CE: EN 1078 - CP: SC 1203)
SIZE: 2 sizes available
WEIGHT: Gr. 280



FLUO BLUE PRO RACE KIT

PRO RACE JERSEY AND BIB PANTS (extra slim fit)

Excellent breathability & quick drying properties/ full front zip YKK / three compartment rear pocket / soft silicone band on sleeve edge and lower jersey edge / anti-slip silicone band on legs / CoolMax® padding / anatomic multi-panel cut / brace construction made from breathable mesh / soft internal overlapped stitching for comfort. Composition: 90% Polyester 10% Elastane
Size: S-M-L-XL-XXL





SUNSET PRO RACE KIT

PRO RACE JERSEY AND BIB PANTS (extra slim fit)

Excellent breathability & quick drying properties/ full front zip YKK / three compartment rear pocket / soft silicone band on sleeve edge and lower jersey edge / anti-slip silicone band on legs / CoolMax® padding / anatomic multi-panel cut / brace construction made from breathable mesh / soft internal overlapped stitching for comfort. Composition: 90% Polyester 10% Elastane
Size: S-M-L-XL-XXL



BASSO CYCLING CAP

100% cotton



BASSO LOGO CAP

100% cotton
 Rear adjustment



BASSO RACING SOCKS

Arch support for good fit / Cushioned panels for comfort and support / Flat toe seam to avoid pressure or irritations / unisex
Size: 39-41 / 42-44 / 45-47



ALIANTE HELMET FLUO

Basso Aliante's structure is based on an innovative design approach which focuses on particular performance parameters of the helmet such as being compact, aerodynamic, ventilated and lightweight. TECHNOLOGY: In-Mould, Adjustable Rol Loc Retention.

CERTIFICATION: (CE: EN 1078 - CP: SC 1203)

SIZE: 2 sizes available

WEIGHT: Gr. 280



DARK COMFORT KIT

RACE JERSEY AND BIB PANTS (comfort Fit)

We celebrate our 40th year anniversary and have already presented a special Diamante which gets the inspiration from Basso 1982 GAP model.

In connection with this, we proudly launch our new clothing range including 1977 Racing Jersey, which has a regular fit for the ones who like to have casual cycling clothing with Retro fonts and graphics.

SIZE: S-M-L-XL-XXL

LUNAR BLUE COMFORT KIT





MID SEASON JERSEY VENTI

Double-layer fabric insulation with soft and warm interior / fully zipped rear and front pocket / ergonomic sleeves cut / inside flap to block wind / flat seams
Size: XS-S-M-L-XL-XXL



MID SEASON VEST VENTI

Double-layer fabric insulation with soft and warm interior / fully zipped rear and front pocket / ergonomic sleeves cut / inside flap to block wind / flat seams
Size: XS-S-M-L-XL-XXL



WIND VEST VENTI

Light and foldable is perfect for your back pockets / reflective back stripes / perfect ventilation with the air panels on your back.
SIZE: S-M-L-XL-XXL



**POCKET TEE 100% COTTON
ITALIAN RACE PASSION**

SIZE: S-M-L-XL-XXL



**POCKET TEE 100% COTTON
B LOGO**

SIZE: S-M-L-XL-XXL

**TEE 100% COTTON
ITALIAN RACE PASSION**

SIZE: S-M-L-XL-XXL



**TEE 100% COTTON
WHITE LOGO**

SIZE: S-M-L-XL-XXL



CARBON MONEY CLIP

Exclusive BASSO BIKES design.
Slim and light, made of carbon fiber.



Basso Bikes is a family owned business and this family feeling is really transmitted into our products. Whenever we ride our bike out on the streets and we cross someone on a Basso bike, it feels as if that person is part of our group of riders. For this reason we have created "Famiglia Basso Bikes", an exclusive and unique Basso Bikes members club. Every Basso Bike owner can be part of Famiglia Basso Bikes, no matter if you have a brand new or an old Basso bike.

Basso bikes è una azienda a conduzione familiare e ogni nostro prodotto viene trattato come parte della nostra famiglia. Ogni volta che incrociamo un atleta che pedala su una bici Basso è come se facesse parte della nostra famiglia. Per questo motivo abbiamo deciso di creare un gruppo sportivo esclusivo e aperto ai possessori di una bici Basso. Questo gruppo si chiama "Famiglia Basso Bikes". Tutti i proprietari di una bici Basso possono fare parte di Famiglia Basso Bikes indipendentemente dal fatto che la loro bici sia nuova o d'epoca.

You can register on our website and you will have access to a 12 month membership, which includes exclusive advantages and a special Famiglia box, with limited Famiglia items, like an exclusive cycling jersey and bibs kit. The year registration to Famiglia Basso Bikes will also give you access to some really nice advantages, like the extension of the warranty on your bike. Famiglia Basso Bikes registration will give you access also to our Basso Bikes Club House in the Dolomites in Cortina d'Ampezzo where you can ride with your friends in one of the best cycling destinations in the world.

Potete registrarvi sul nostro sito ed accedere ad una membership di 12 mesi che vi darà numerosi vantaggi. Pochi giorni dopo la registrazione riceverete a casa una speciale Famiglia Box contenente un kit di abbigliamento esclusivo riservato ai membri di Famiglia Basso Bikes, e molto altro. Con la registrazione al nostro club potrete inoltre estendere gratuitamente la garanzia della vostra Basso. Con Famiglia Basso Bikes potrete avere accesso alla nostra Basso Bikes Club house. Un esclusivo chalet nelle Dolomiti Ampezzane dove pedalare con i vostri amici immersi in un territorio magnifico.

Famiglia Basso Bikes is more than a group of riders with something in common. Famiglia Basso Bikes is something special dedicated to those who love our bikes and our brand. Join Famiglia Basso Bikes!

Famiglia Basso Bikes è molto più di un semplice gruppo sportivo, è una vera e propria Famiglia creata per tutti voi che amate il marchio Basso Bikes!

MICROTECH WHEELS - PROUDLY MADE IN ITALY



M138 **CARBON tubular**

Hubs: 18-24 holes with carbon body
 Front: 38 mm
 Rear: 38mm
 Rim: full carbon 3K
 Spokes: Sapim
 Kit: wheels bag and brake pads.

WEIGHT: 1195 gr. +/- 3%



MR38C **CARBON clincher**

Hubs: Alloy 18-24 holes
 Front: 38 mm
 Rear: 38 mm
 Rim: UD carbon fibre
 Spokes: Sapim
 Kit: wheels bag and brake pads.

WEIGHT: 1656 gr. +/- 3%



MR38 DISC **CARBON**

Hubs: 24-24 holes c/lock
 Front: 38 mm
 Rear: 38 mm
 Rim: UD carbon fibre
 Spokes: Sapim
 Kit: wheels bag and brake pads.

WEIGHT: 1625 gr. +/- 3%



MTT **CARBON tubular**

Hubs: 18-24 holes with carbon body
 Front: 50 mm
 Rear: 88 mm
 Rim: full carbon 3K.
 Spokes: Sapim black stainless steel

WEIGHT: 1463 gr. +/- 3%



REAR DISC **CARBON tubular**

Rim: full carbon 3K
 Available for TT or Pista

WEIGHT: 1200 gr. +/- 3%



MR LITE DISC **ALLOY**

Hubs: Alloy 24-24 holes
Front: 25 mm
Rear: 25 mm
Rim: alloy
Spokes: Sapim black stainless steel
Tubeless Ready

WEIGHT: 1683 gr. +/- 3%



MCT DISC **ALLOY**

Hubs: Alloy 24-24 holes
Front: 30 mm
Rear: 30 mm
Rim: alloy
Spokes: Sapim black stainless steel
Tubeless Ready

WEIGHT: 2030 gr. +/- 3%



MCT38 **ALLOY**

Hubs: Alloy 16-24 holes
Front: 35 mm
Rear: 35 mm
Rim: alloy
Spokes: Sapim black stainless steel

WEIGHT: 1730 gr. +/- 3%



KRIUM **ALLOY**

Hubs: 20-28 holes
Front: 25 mm
Rear: 25 mm
Rim: alloy
Spokes: Sapim stainless steel

WEIGHT: 1985 gr. +/- 3%



SEAT POST DIAMANTE CARBON

-25 mm offset
(to fit with Diamante only).

SEAT POST DIAMANTE SV CARBON

-25 mm offset
(to fit with Diamante SV only).

SEAT POST ASTRA/PALTA CARBON

-15 mm offset
(to fit with Astra and Palta).

SEAT POST VENTA ALLOY

-15 mm offset
(to fit with Venta only).



DIAMANTE STEM -11°

Material: alloy 6061 forged - Angle: -11°
Size: 90-100-110
120-130 - Colors: black
Weight 185 gr (110 mm) +/- 5%



DIAMANTE STEM 0°

Material: alloy 6061 forged - Angle: 0°
Size: 90-100-110
120-130 - Colors: black
Weight 185 gr (110 mm) +/- 5%



VENTA STEM

Material: alloy - Angle: 7°/84° - Size: 80-90-100-110
120 Color: black - Weight: 155 gr +/- 5%



"INTEGRA" HANDLEBAR

Increased integration has become increasingly important and it serves to not only maintain a clean aesthetic but also for improved functionality. The INTEGRA is a solution that manages to improve both aesthetics and functionality in one single, finely crafted carbon integrated stem/bar system. Aside from cleaner lines, and fewer additional pieces than traditional systems, this particular integrated handlebar system mimics perfectly the look of what is arguably the industry's most beautiful stem, thus matching perfectly with the head-turning design of both the Diamante and Diamante SV. Cables route internally and the design has been optimized for the Shimano Di2 handlebar junction box, thus resulting in an even cleaner cockpit. While its appearance will turn heads it is perhaps the functionality of this sophisticated component that renders it coherent for the superbike category. Made with the same high modulus Torayca carbon fiber used in the construction of the Diamante frame, it is stiff and strong enough to handle the tug of the toughest sprinter and aerodynamic in form to reduce drag to a minimum. The INTEGRA looks fast because it is fast and as such it is the perfect addition to your finely crafted superbike from Basso. Stem angle is fixed at -8°. Sizes are scaled as follows: 420mm out-out bars = 90mm or 100mm stem; 440mm out-out bars = 100mm, 110mm or 120mm stem; 460mm out-out bars = 120mm or 130mm stem.

Una maggiore integrazione di linee e funzionalità fra le varie parti della bici è sempre più ricercata non solo per mantenere un'estetica pulita ma anche a migliorare le prestazioni. INTEGRA migliora nella bicicletta sia l'estetica che la funzionalità integrando in un unico sistema attacco e manubrio di altissimo pregio e lavorazione. Oltre alle linee più pulite e minor pezzi per cui minor peso rispetto ai sistemi tradizionali, il manubrio INTEGRA imita perfettamente l'estetica di quello che è probabilmente lo stem più bello del settore, riprendendo le linee di design rivoluzionario sia del Diamante che del Diamante SV. I cavi passano internamente dove può alloggiare anche la scatola di giunzione Shimano Di2, rendendo l'insieme ancora più pulito. Il design è tanto bello quanto funzionale, un accessorio che bene si abbina ai telai di altissima gamma. Realizzato con la stessa fibra di carbonio alto modulo Torayca utilizzato nella costruzione del telaio Diamante, è rigido e forte per reggere le spinte di uno sprinter e di forma aerodinamica per ridurre al minimo la resistenza all'aria. INTEGRA non sembra veloce, INTEGRA ti rende veloce e come tale è l'aggiunta perfetta alla tua superbike finemente realizzata da Basso.

L'angolo dell'attacco manubrio è a -8°. Disponibile nelle misure: manubrio da 420mm est-est = attacco manubrio da 90mm o 100mm; manubrio da 440mm est-est = attacco manubrio da 100mm, 110mm o 120mm; manubrio da 460mm est-est = attacco manubrio da 120mm o 130mm.



HANDLEBAR QUANTUM COMPACT

Material: carbon T700 - Size: 420,440,460 out/out
Drop: 120 mm, Reach: 70 mm
Color: carbon black - Weight: 240 gr. +/- 5%
Di2 internal cable routing also available.



HANDLEBAR XL

Material: alloy - Size: 400,420,440,460 out/out
Drop: 120mm, Reach: 70 mm
Color: black - Weight: 280 gr. +/- 5%



GPS HANDLEBAR SUPPORT FOR "INTEGRA" HANDLEBAR

- Secures your computer in front of your bike handlebar to optimize viewing system
- Heads-up positioning provides increased safety
- Compatible with Garmin head units
- Direct mount on INTEGRA handlebar by the dedicated slot in the lower front side
- Material: aluminum. Weight: 25 grams.



PALTA CHAIN GUIDE

Aluminum chain guide available for our Palta bike.
To avoid chain drop in tough situations.

Guida catena in alluminio disegnato per il telaio Palta.
Utile per evitare la fuoriuscita della catena in terreni particolarmente insidiosi.



SERVICE KIT - COMPATIBLE WITH ALL FRAMES

Set of rubber caps and cable stops, compatible with all models, to transform your frame from mechanic to Di2/Eps, or vice-versa.

The service set includes an aluminum chain catcher, to avoid chain drop to ruin your frame's BB shell area. Set of bolts helps to fix it to the front derailleur mount



DIAMANTE SEATPOST BATTERY SUPPORT

Soft long lasting rubber



DIAMANTE SV SEATPOST BATTERY SUPPORT

Soft long lasting rubber



CARBON SPACER 5MM

5mm Carbon Spacer with Basso logo.
Designed specifically for Diamante SV, Diamante and Astra stem.
Colors available: white, red, green, black, orange fluo.



CARBON BOTTLE CAGE

Weight: 25 gr. +/- 5%
Color: carbon, fluo yellow, fluo orange, gray.



HANDLEBAR RIBBONS

Basso logo embossed - Backside/center adhesive strip for easy mounting. Colors: white-black-yellow-blue



GPS HANDLEBAR SUPPORT

- Secures your computer in front of your bike handlebars to optimize viewing system
- Heads-up positioning provides increased safety
- Compatible with Garmin head units
- Easy to install by two lower bolts on your stem's face plate.
- Material: aluminum. Weight: 25 grams.



BOTTLE

Basso Water Bottle. 500cc
Color: gray, fluo yellow





BASSOBIKES

Via San Martino 25,
31020 San Zenone d. Ezz. (TV) - Italy
Tel. +39 0444 590033
info@bassobikes.com
WWW.BASSOBIKES.COM



BASSO INTERNATIONAL WARRANTY

Garantiamo ogni nostro prodotto con marchio BASSO o MICROTECH da difetti di produzione, per un periodo di 36 mesi dall'acquisto del primo proprietario. Per ottenere l'attivazione della copertura in garanzia l'acquisto deve essere comunicato entro 10 giorni dalla data di acquisto a mezzo posta all'indirizzo indicato nel cartoncino allegato ad ogni bici o telaio, oppure essere registrato nel sito www.bassobikes.com nella pagina "warranty". Le condizioni generali di garanzia sono disponibili per la consultazione online o per la stampa direttamente nel sito.

We warranty our products, branded BASSO or MICROTECH, from production defects for a period of 36 months from the date of the original proprietor purchase. To obtain the warranty coverage the purchase must be reported to us within 10 days. It can be done by post service, sending the form attached to every bike or frame. Purchase can also be registered on our web site www.bassobikes.com in the web page "warranty". General terms of warranty are available to read or download and print in our web pages.

IT IS IN BASSO BIKES POLICY TO CONDUCT ALL OF OUR OPERATIONS IN AN ENVIRONMENTALLY RESPONSIBLE AND SUSTAINABLE MANNER; TO COMPLY WITH ENVIRONMENT LAWS AND REGULATIONS; TO REDUCE ITS USE OF RESOURCES AND GENERATION OF WASTE; TO STRIVE FOR CONTINUAL IMPROVEMENT.

Basso has the right to make improvements and/or modifications to its products without prior notice.
Basso si riserva il diritto di apportare migliorie e/o modifiche ai prodotti senza alcun obbligo di preavviso.

BASSO-MICROTECH-DIAMANTE SV-DIAMANTE-ASTRA-VENTA-PALTA-KONOS-PURPLE LABEL are trademarks of BASSOBIKES S.r.l.